



Product Introduction

MEGA SLURRY

Application

The GIW Mega Slurry is a high-performance, low-maintenance slurry pump recommended for coarse or fine particles from solids-laden waste water to aggressive slurries of an abrasive and/or corrosive nature. Consult factory for corrosive applications.

Design

Horizontal, end suction, modified volute casing pump includes three vane, open design impeller for large solids passage and good wear characteristics over a broad operating range. The single stage, compact arrangement allows easy maintenance of wet end components. The back pull-out design permits removal of the mechanical end without disturbing the wet end or piping.

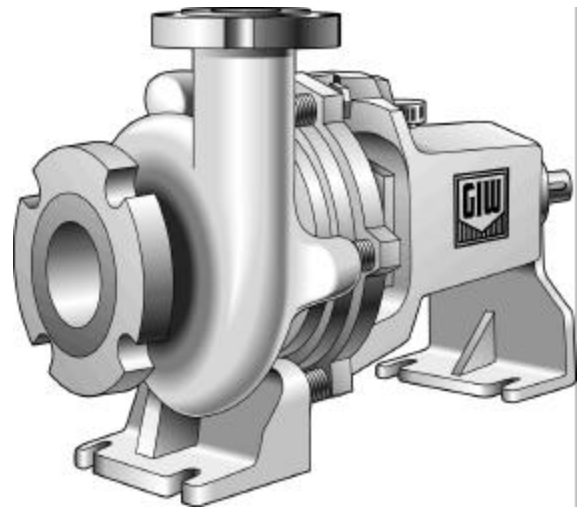

Designation

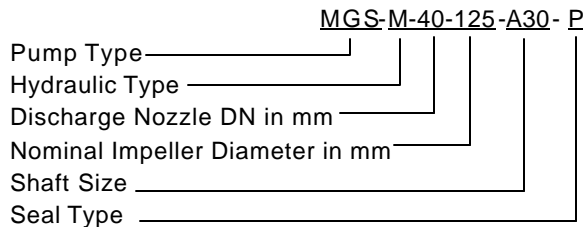

Pressure, Free Passage & Temperature Limits

Seal Type	Maximum	Free Passage
Mega Slurry 40-125		
Packing	15.9 bar - 230 psi	19 mm - .75 in
Mechanical Seal	10 bar - 145 psi	19 mm - .75 in

Rotation Direction: Clockwise as seen from drive end
 Position of Discharge: Vertical only

Hydraulic Type

M.....Metal

Shaft Size - A30

Seal Type

P.....Packing

M.....Mechanical Seal

Operating Limits

Pump Size	Discharge	40mm (1.5 in)
Capacity	Q max.	45m ³ /hr (200 gpm)
Head	H max.	30 m (100 ft)

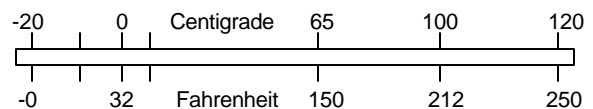
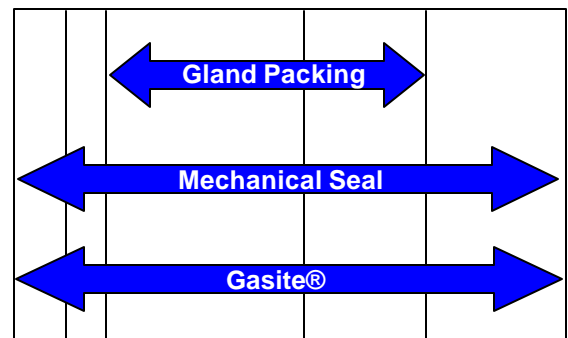

MEGA SLURRY

Materials

Part No.	Description	Standard Pump (M1)	Corrosive Applications (MC2)
101	Casing	Gasite 27G	Gasite T90G
135	Wear Plate	Gasite 27G	Gasite T90G
161	Casing Cover	Gray Iron 40C	Gray Iron 40C
210	Shaft	1045 Steel	Stainless Steel
230	Impeller	Gasite 27G	Gasite T90G
332	Pedestal Leg	Gray Iron 40C	Gray Iron 40C
350	Bearing Housing	Gray Iron 40C	Gray Iron 40C
452	Gland	Gray Iron 40C	*
458	Lantern Ring	Gray Iron 40C	*
524	Shaft Sleeve	Heat Treated Alloy	Stainless Steel
	Wet End Fasteners	Carbon Steel	Stainless Steel
	Lubrication	Oil	Oil

*Several options are available. Please consult factory (*Mechanical seal option or special alloy)*

